

Product Information

The Troffer.F is a rectangle, recessed LED fixture that provides uniform illumination in commercial settings.

This fixture features die-formed and embossed code 22 gauge steel with white reflectors.

The Troffer.F is the perfect LED fixture for Conference Rooms, Interior walkways, Retail Spaces and a variety of other indoor lighting applications.

Performance Ratings and Certifications

UL 1598
 UL 8750
 CSA C22.2#250.0
 CSA C22.2#250.13
 IP Rating: IP40

Performance Summary

Lumens: 4,308 – 8,615 lm
 Lumens Per Watt (typ): 110 LPW
 Power Consumption: 39 - 78 W
 Light Engine: L70 Rated Lifetime of 100,000+ hours.
 CRI: Minimum 80 CRI. Optional custom CRI.
 CCT (Typical): 3000K, 4000K, 5000K, tight bins also available.
 Manufactured in the U.S. with parts from U.S. and imported.



Fixture Information

Housing: Die-formed and embossed code 22 gauge steel.
 High reflectance baked white enamel.
 Color: Custom colors also available.
 Lens: High transmission prismatic pattern #12 acrylic (A12) for light diffusion which maximizes light output. Other lenses are available upon request. See fixture specifications page for details.
 Mounting: Recessed inverted T-Bar ceilings. Grid mount or surface mount. Wiring knockouts are provided on the back of housing.
 Length: 48"
 Width: 12"
 Depth: 4"

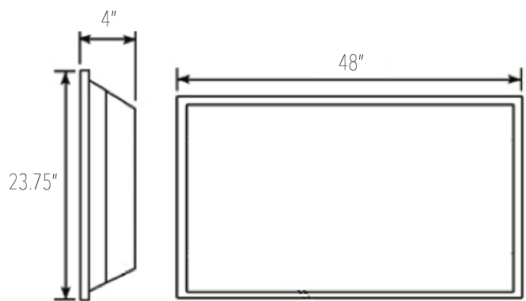

Electrical System Characteristics / Data

AC Input: 120/277 VAC (standard), 480 VAC (upgrade)
 FCC: Title 47, Part 2, Part 15, Class A
 EM: Compliance to EN55015, EN55022 (CISPR22) Class B, EN61000-3-2 Class C (60% load); EN61000-3-3
 EM Immunity: Compliance to EN61000-4-2, 3, 4, 5, 6, 8, 11, EN61547, EN55024, light industry level (surge 4KV), criteria A
 Withstand Voltage: I/P-O/P: 3.75KVAC I/P-FG: 2KVAC O/P-FG: 1.5KVAC
 Isolation Resistance: I/P-O/P, I/P-FG, O/P-FG: 100M Ohms / 500VDC / 25 / 70% RH
 Power Factor: PF > 0.98/115VAC, PF > 0.92/277VAC
 Total Harmonic Distortion: THD < 20%
 Standard Surge Protection: All-Around Protection: OVP, SCP, OLP.
 Enhanced Surge Protection: Protects against surges according to IEEE C62.41.2 C and ANSI C136.2
 Emergency Battery Backup: Optional upgrades available.

Optional Controls:

Wireless Controls: Optional via Pulse Wireless Mesh Network
 Dimming: 0-10V, step, line voltage and bi-level available.
 Daylight Harvesting Sensor: Optional.
 Occupancy Sensor: Optional.

Warranty

Five-Year Limited Warranty. Optional 10-Year Manufacturer's Warranty Available. Full Warranty Terms Available At www.noribachi.com/products/warranty

Electrical System Specifications

Electrical Load				
Light Engine	Drive Current (Amps@120VAC)	Drive Current (Amps@277VAC)	Drive Current (Amps@480VAC)	System Power (Watts)*
LINL-112-B	0.33	0.14	0.08	39.16
LINL-224-B	0.65	0.28	0.16	78.32

*ideal wattage

Operating Characteristics (Typical @5700K CCT)				
Light Engine	Lumens (Medium Dist)	Input Power (Watts)	Lumens per Watt	Replaces
LINL-112-B	4,308	39.16	110.00	400-750W
LINL-224-B	2,154	78.32	110.00	1050-1500W

Fixture Specifications

Construction

Die-formed and embossed 22 gauge steel with high reflectance baked white enamel and matte white reflectors.

Optional Finishes

Custom colors available (specify RAL code). Epoxy finish and marine-grade coating available. Marine grade coating is green.

Mounting Options

Recessed inverted T-Bar ceilings. Grid mount or surface mount. Wiring knockouts are provided on the back of housing.

Lens Options

High transmission prismatic pattern #12 acrylic (A12) for light diffusion which maximizes light output. Other lenses are available upon request. See fixture specifications page for details.

Light Distribution Patterns

T5 standard.

Electrical System Specifications

Electrical System

Standard AC input of 120 – 277VAC. Optional upgrade to 480VAC. Driver meets maximum harmonic distortion (THD) of 20% and is ROHS compliant. Power Factor = > 0.9. Standard Surge protection according to IEC/EN 61000-4-5 EMC test standard and can protect against up to 4KV transient surge. Optional, enhanced Surge Protection protects Line-Ground, Line-Neutral, and Neutral-Ground. Protects against surges according to IEEE C62.41.2 C(10kA and 10kV) and ANSI C136.2.

Controls

Optional controls include: 0-10V (010V), Step, line voltage and Bi-Level Dimming functionality (not guaranteed to work with all dimming systems). Occupancy and Daylight Harvest Sensors available. Optional Emergency Battery Backup: Nickel-Cadmium Batteries, 5W, 600 Lumens for 90 minutes. Optional Cold Emergency Battery Backup: 23W, 2000 Lumens for 90 minutes. The battery has a 7-10 year lifespan.

Driver

All LED drivers provide constant current to give flicker free lighting. Two different drive currents are provided; A (350 mA) and B (525 mA). Highly reliable. Suitable for dry, damp and wet locations. Compliant to worldwide safety regulations for lighting.

Ambient Temperature

We provide fixtures that can sustain ambient temperature ranging from -40F to 140F (-40C to 60C).

Wireless Control Options

Optional wireless networking using the Noribachi Pulse Wireless controller. Pulse is an Arduino-based hardware platform that provides communication between fixtures and a base station using Digi's XBEE based mesh network. Pulse controls up to 16 independent LED lighting fixtures using an FCC approved 900 MHz frequency with up to 200 Kbps data transmission speed. Transmit power output 50 mW. Data transmission rate is 156.25 kbps. 128 bit AES Encryption.

Occupancy Sensor and Daylight Harvesting

Sensor provides 60' diameter coverage from a 40' height. Time can be set from 30 seconds to 30 minutes.

RGBW Controls

Optional RGBW controls with communication to fixture via DMX512 or DMX256 and four channel controls. Four channel control uses red, green, blue and white (to control intensity). DMX controller optional, either software DMX master (via CD and USB adapter) or a physical DMX master. 2.4 GHz wireless DMX networking optional. Other frequencies available upon request.

Testing Compliance

Noribachi complies with and exceeds standards set forth by UL and CSA. All luminaires comply with UL 1598 (CSA C22.2#250.13), and UL 8750 (CSA C22.2#250.0) standards for safety. Performance testing is done in accordance with LM-79 color measurements and LM-79 distribution measurements, and LM-80 lumen maintenance testing.

Manufacturing

Manufactured in beautiful Harbor City, CA. ARRA Compliant. NAFTA Compliant. Test and burn-in of 100% of all luminaries before shipment. No less than 8-years experience in manufacturing LED-based products.

Warranty

Standard limited 5-year warranty, first year includes labor. Optional 10-year warranty available. See details at www.Noribachi.com.

Note

All safety tests and performance data is done in ambient (STP) conditions. Specifications subject to change without notice. Actual performance may differ as a result of end-user environment application. Actual wattage may differ by +/- 8%. Lumen values may vary within compliance with ANSI C78-377 (unless specifying tight color bins).



Optics Specifications

White LED Optics

High brightness, high efficiency LEDs. Standard color temperature is Cool White (5000K typical). Neutral White (4000K typical) and Warm White (3000K typical) also available. All with minimum 70 CRI. Tight bins ($\pm 50\text{degK}$ variability) also available – recommended for WW installations as the eye is sensitive to variations in this color range. 40deg and 80deg beam angle optional (n/a for RGBW).

RGBW Light Engine Optics

RGBW light engine also available, compatible with DMX controller. RGBW colors, to allow changing from pure white light to any hue available. Multiple channels of LEDs produce a full spectrum of light anywhere from deepest red to farthest violet. CRI greater than 75 in the 2700K – 4000K range.

Single color light engines also available. Red=630 nanometers, Green=525 nanometers. Blue=475 nanometers.

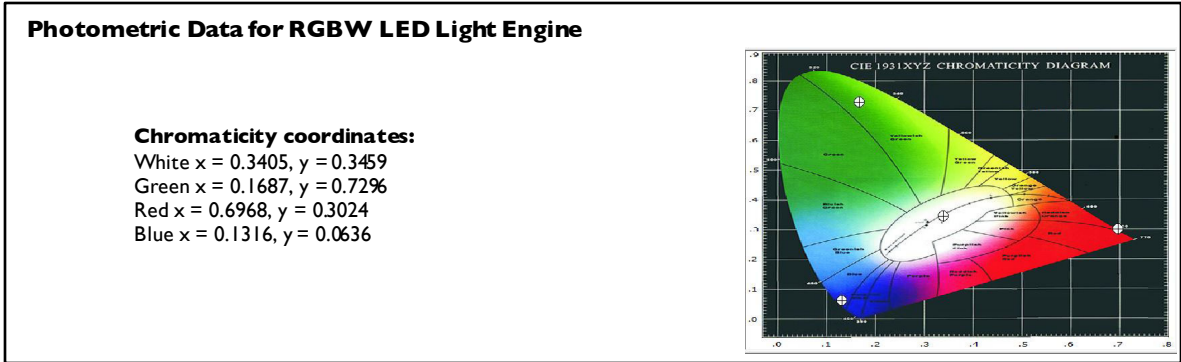
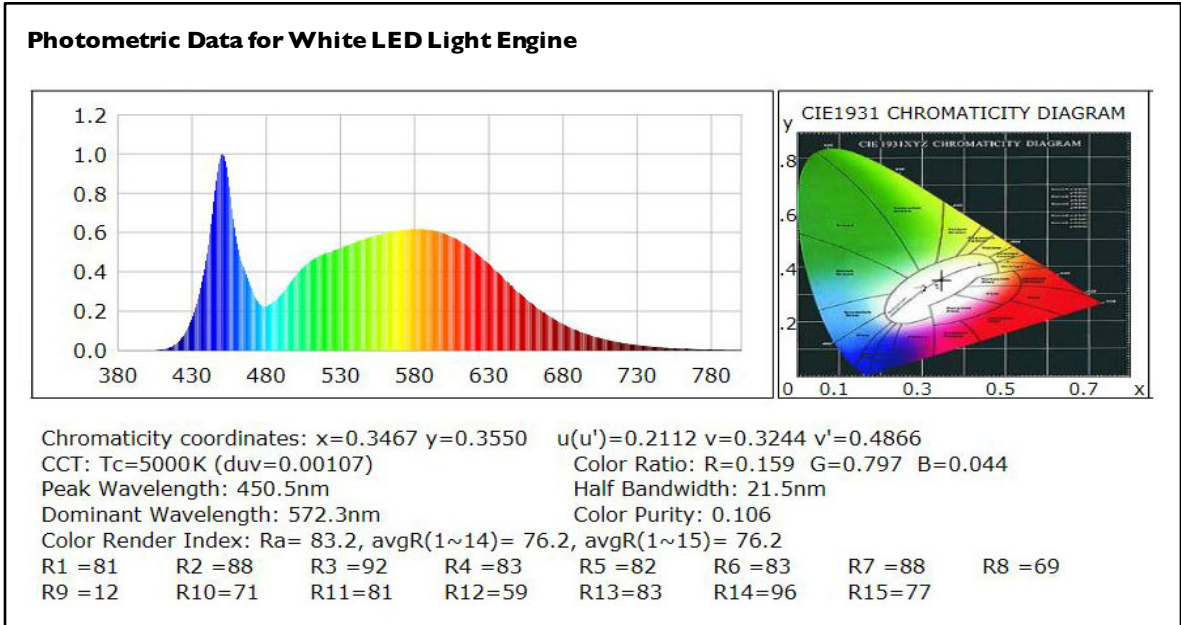

How to Order

Sample Order Code: Only include the optional upgrades you need.

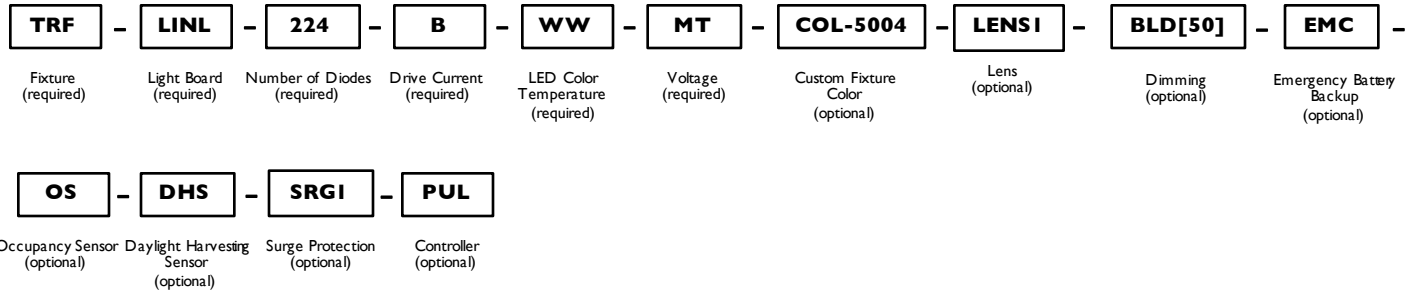

Numbering Order	Specification	Required or Optional	Allowed Values	Description
1	Fixture	Required	TRF	For Troffer.F
2	Light Board	Required	LINL	For LINL
3	Number of Diodes	Required	112	For LINL-112
			224	For LINL-224
4	Drive Current	Required	B	B (525mA) drive current
5	LED Color Temperature	Required	CW	Standard Cool White LEDs (5000K)
			NW	Neutral White LEDs (4000K)
			WW	Warm White LEDs (3000K)
			[Specific degree Kelvin]	Specific color temp LEDs [Specific degree Kelvin]
			TB1 [Specific degree Kelvin]	Tight Bin LED Color [Specific degree Kelvin]
			TB2 [Specific degree Kelvin]	Tight Bin LED Color [Specific degree Kelvin]
			RGBW	Red/Green/Blue/White light engine
6	Voltage	Required	SCOL [R/G/B]	Single color light engine
			MT	Standard AC input: 120VAC - 277VAC
			HV1	High Voltage (480VAC)
7	Custom Fixture Color	Optional	HV2	High Voltage (480VAC)
			COL-[RAL]	Custom Fixture Color (RAL code)
8	Lens	Optional	LENS1	Prismatic Acrylic #12 Pattern 1/8"
			LENS2	Matte White Acrylic
			LENS3	Specular Parabolic Louver 1/2" x 1/2" x 3/8"
			LENS4	Specular Parabolic Louver 3/4" x 3/4" x 1/2"
			LENS5	Specular Parabolic Louver 1 1/2" x 1 1/2" x 1"
			LENS6	White Cubed Acrylic Louver 1/2" x 1/2" x 3/8"
			LENS7	Frosted Acrylic Smooth Lens .04", 100% Durafrost
9	Dimming	Optional	010V	0-10V dimming
			STEP	Step dimming
			BLD [%]	Bi-level dimming
			LVDIM	Line voltage dimming
10	Emergency Battery Backup	Optional	EM	Emergency Battery Backup
			EMC	Emergency Battery Backup, Cold
11	Occupancy Sensor	Optional	OS	Occupancy Sensor
12	Daylight Harvest Sensor	Optional	DHS	For Daylight Harvest Sensor
13	Surge Protector	Optional	SG1	Enhanced surge protector for 120-227VAC
			SG2	Enhanced surge protector for 480VAC
14	Pulse Wireless Controller	Optional	PUL	Pulse Wireless Controller