



HAZARDOUS LOCATIONS LIGHT SPECIFICATION



E Series



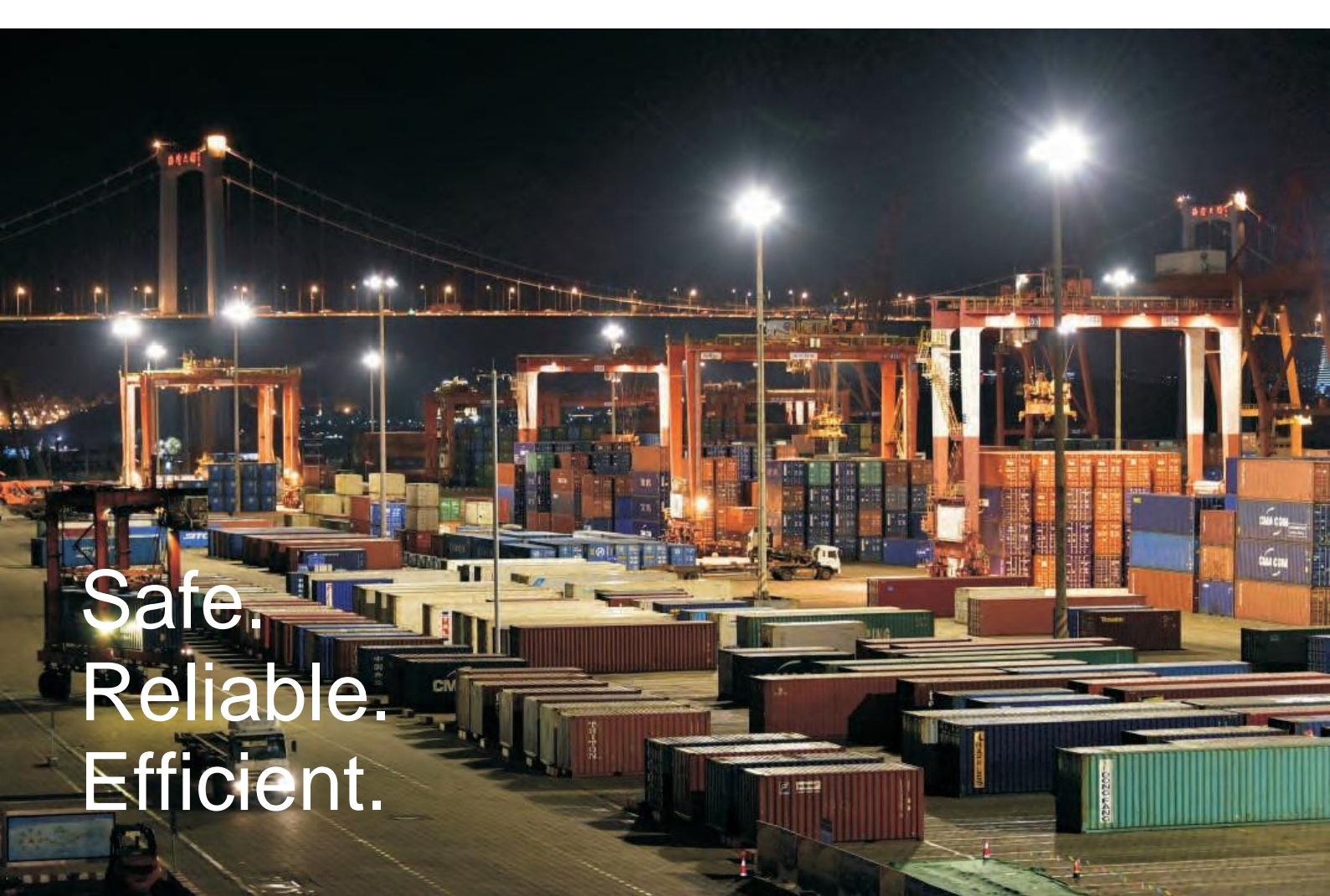

Safe.
Reliable.
Efficient.

Ratings and Certifications

- NEMA 4X, IP66
- UL1598/UL1598A/UL844
- CSA C22.2 No.137/No.250.0
- Class I, Division 1, Groups C, D
- Class I, Division 2, Groups A, B, C, D
- Class II, Division 1, Groups E, F, G
- Class II, Division 2, Groups E, F, G
- Class III
- Marine and Wet Locations
- IECEX
- ATEX
- 5 years or other warranty period specified in agreement
- L70 rating for more than 150000 hours

Applications

This luminaire can be used as flood light, wall pack and area light which can provide general illumination in hazardous locations, such as:

1. Oil refineries and Gas station
2. Oil and gasoline loading dock
3. Distillery
4. Painting manufacturing plant
5. Pumping station
6. Mine
7. Vessel
8. Other high humidity, high temperature, dusty location

Professional Light Distribution

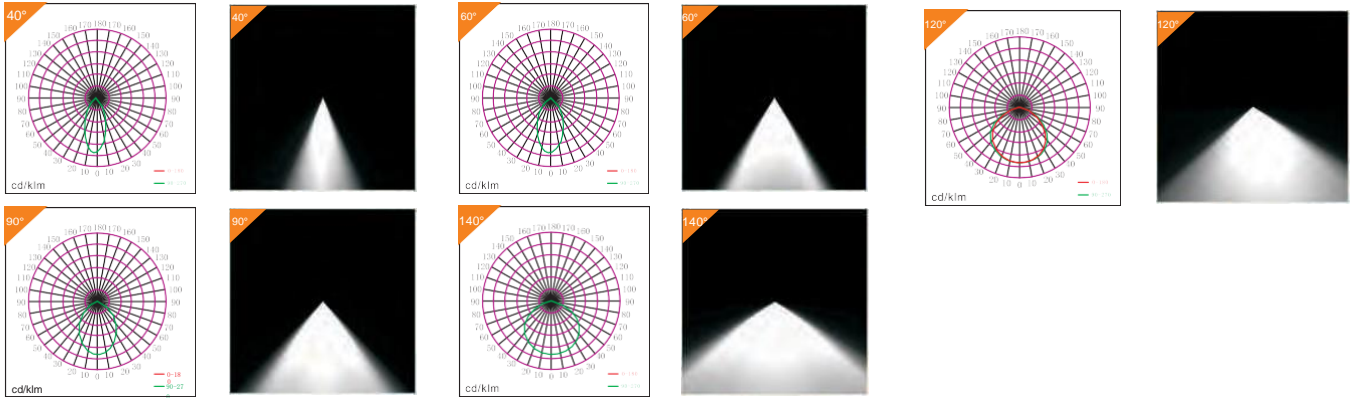

Typical model specification

Product Number	Wattage	CCT	Voltage	Lumens	Working Hours	CRI
EX-40W EYZDA	40	4000K-5700K	AC90-305V	5600	5 years	70
EX-60W EYZDA	60	4000K-5700K	AC90-305V	8400	5 years	70
EX-80W EYZDA	80	4000K-5700K	AC90-305V	11200	5 years	70
EX-100W EYZDA	100	4000K-5700K	AC90-305V	14000	5 years	70
EX-120W EYZDA	120	4000K-5700K	AC90-305V	16800	5 years	70

"E"=Product series "Y"=D or N:Dimmable or non-dimmable "Z"= CCT, from 4000~5700K "D"=Beam angle: 40°, 60°, 90°, 120°

Features

- High efficacy: up to 140lm/W
- CRI>70
- Surface mounting and pendant installation
- Wide and narrow optics for uniform illumination
- Copper free aluminum
- High vibration resistance

Mechanical information

	Size (in)
AC90-305V models	∅ 14×12/23

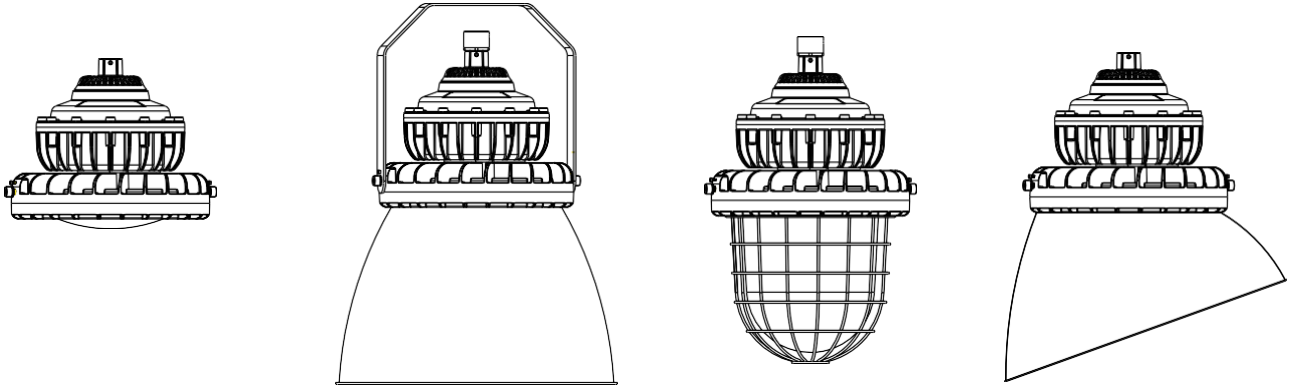
Structure diagram

Mounting method

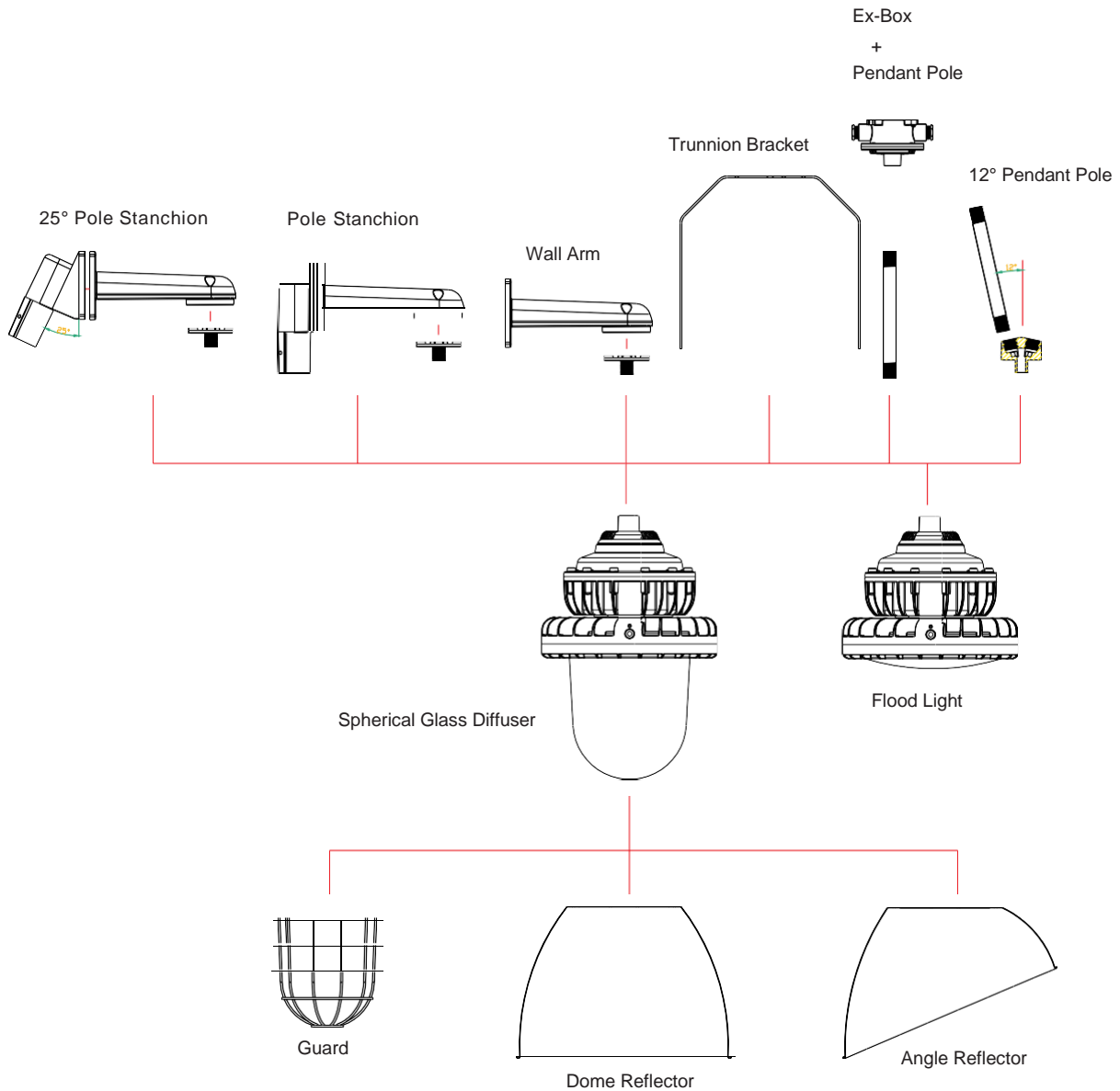

Warranty

Only offer 5 year's warranty or any other warranty period specified in the contract for the product from the date of purchase:

- Invoice or shipment bill is required to claim the warranty.
- The warranty policy only requires manufacturer to repair the defective product or send substitute for replacement.
- Installation labor, electricity cost and other related cost will not be covered by the manufacturer warranty policy.
- Warranty doesn't cover the defect caused by inappropriate use, especially if directions of the instructions for use are not observed, normal abrasion as well as failures which affect the value or use of the product insignificantly.