

PLF Myriad Flood Light

Outdoor

Designed for high-performance safety and security lighting, the Myriad Premium Flood Light is an IP66 rated luminaire rated for long-lasting, low maintenance outdoor function. Parking facilities, landscapes, facades, courtyards, and walkways use the Myriad Premium Flood Light when visibility and safety are top priorities.



Luminaire	Myriad Flood Light	Type
Project		
Product		
Notes		

Features
<ul style="list-style-type: none"> Built from die-cast aluminum Clear glass lens Knuckle, yoke, trunnion and slipfitter mounting

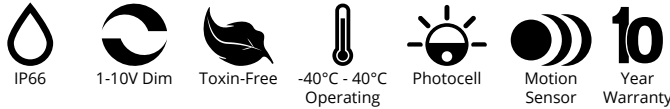

Order Format

Sample: PLF-30-50

Series	Wattage	CCT	Voltage	Dimming	Lens	Finish Color
PLF =Premium Flood Light	30=30W 50=50W 100=100W 150=150W	50=5000K	Blank=100-277V	Blank=1-10V Dimming ND=Non-Dimming	Blank=Clear Lens	XX Blank=Matte Finish

Application

The Myriad Premium Flood Light has multiple mounting options including knuckle, yoke, trunnion, and slipfitter.

Construction

The Myriad Premium Flood Light is crafted from die-cast aluminum. The high structural strength and resistance to corrosion play a major part in providing 50,000 hours of long-term, maintenance-free function. The fixture's containment housing integrates heat management and is rated for operation from -40°C to 40°C.

Electrical

The fixture tests for lumen efficacy of 120 Lm/W or greater. Input voltage is available in a standard 100-240/277V, with 347-480V drivers as an option. Superior thermal management allows electrical and optical components to operate at optimal efficiency with exceptional component longevity. Fixture lifespan is rated for 80,000 hours or greater.

Input Voltage (VAC)	100-240/277
CRI	70+
CCT(K)	5000
PF	>.9
THD	<20%
L70 (Hours)	80,000
Color	Matte Black
Housing	Die-Cast Aluminum
Optic Type	Clear Lens
Temperature Range	-40°C to 40°C
Warranty	10 Years

*contact sales for lead time **Type IV not DLC listed

Optics

The clear glass lens and polished reflector deliver create uniformly intense light distribution. CRI is a superior 70, providing safe, comfortable illumination when the Flood Light is the sole source of light. The luminaire is available in 5000K CCT, ideal for clear nighttime visibility.

Certifications

- DLC Premium
- UL listed
- CE
- Title 24
- IP66 rated

Lumen Data		
Wattage (W)	5K	
	Efficacy (Lm/W)	Lumens (Lm)
30W	119	3,570
50W	124	6,200
100W	119	11,900
150W	119	17,850

*contact sales for pricing on 100W and 200W

Catalog Number	SPD	EPA	NEMA Beam
PLF-30-XX	10KV Optional	0.4	H7V6
PLF-50-XX	10KV Optional	0.4	H7V6
PLF-100-XX	10KV Optional	1	H7V7
PLF-150-XX	10KV Optional	1	H7V7
PLF-180-XX	10KV Optional	1	H7V7

Dimensions

**30W
50W**

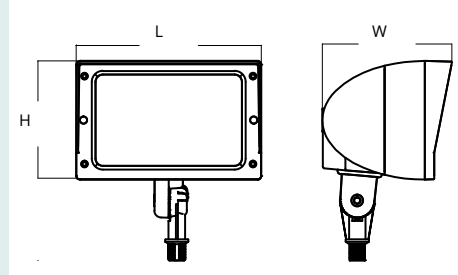

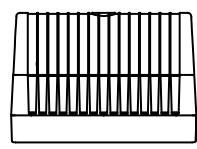

Part No.	Length (L)	Width(W)	Height(H)
PLF-30-50	8.7	6	5.6
PLF-50-50	8.7	6	5.6

Recorded in inches

**100W
150W**

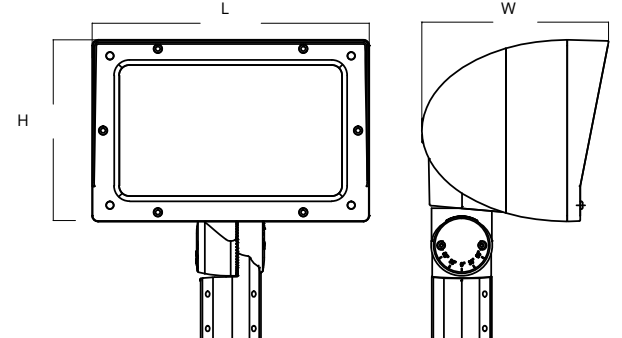

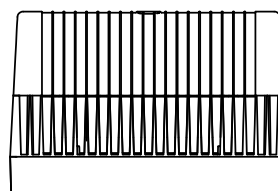

Part No.	Length (L)	Width(W)	Height(H)
PLF-100-50	13.6	9	8.9
PLF-150-50	13.6	9	8.9

Recorded in inches

Photometric

PLF-30-50

ISOCANDELA CURVES

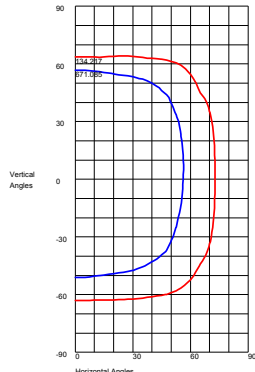

Maximum Candela = 1342.17 Located At Horizontal Angle = 5, Vertical Angle = 0
50% Maximum Candela = 671.085
10% Maximum Candela = 134.217

ISOFOOTCANDLE LINES OF HORIZONTAL ILLUMINANCE

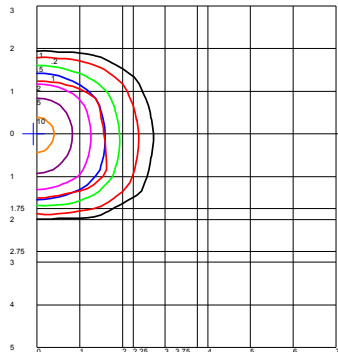

Distance In Units Of Mounting Height
Values Based On 10 Foot Mounting Height
1/2 Maximum Candela Trace Shown As Dashed Curve
(+) = Maximum Candela Point

AXIAL CANDELA DISPLAY

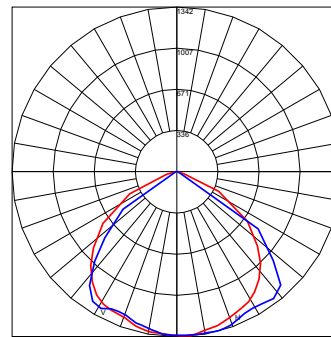

Maximum Candela = 1342.17 Located At Horizontal Angle = 5, Vertical Angle = 0
H - Horizontal Axial Candela
V - Vertical Axial Candela

POLAR GRAPH

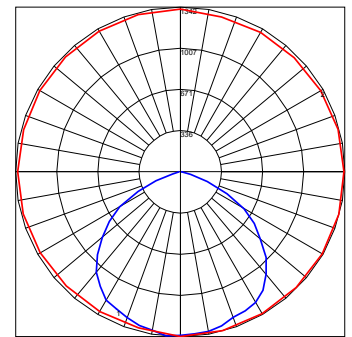

Maximum Candela = 1342.17 Located At Horizontal Angle = 270, Vertical Angle = 5
1 - Vertical Plane Through Horizontal Angles (270 - 50) (Through Max. Cd.)
2 - Horizontal Cone Through Vertical Angle (5) (Through Max. Cd.)

PLF-50-50

ISOCANDELA CURVES

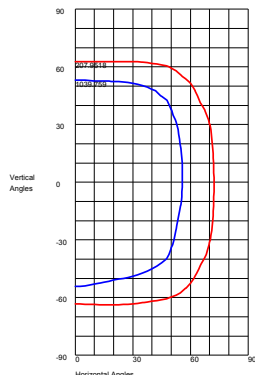

Maximum Candela = 2079.518 Located At Horizontal Angle = 3, Vertical Angle = 9
50% Maximum Candela = 1039.759
10% Maximum Candela = 207.9518

ISOFOOTCANDLE LINES OF HORIZONTAL ILLUMINANCE

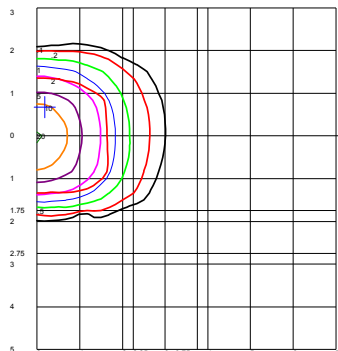

Distance In Units Of Mounting Height
Values Based On 10 Foot Mounting Height
1/2 Maximum Candela Trace Shown As Dashed Curve
(+) = Maximum Candela Point

AXIAL CANDELA DISPLAY

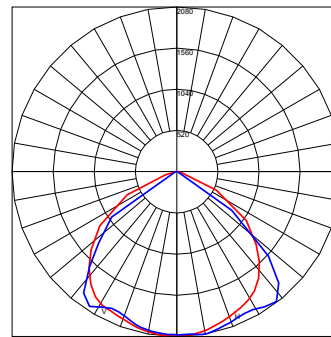

Maximum Candela = 2079.518 Located At Horizontal Angle = 3, Vertical Angle = 9
H - Horizontal Axial Candela
V - Vertical Axial Candela

POLAR GRAPH

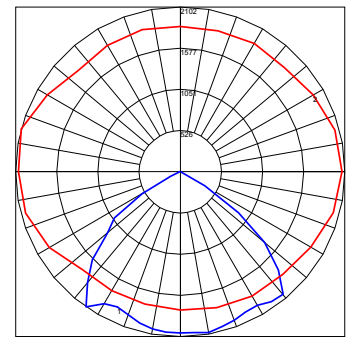

Maximum Candela = 2102.47 Located At Horizontal Angle = 165, Vertical Angle = 35
1 - Vertical Plane Through Horizontal Angles (165 - 34.5) (Through Max. Cd.)
2 - Horizontal Cone Through Vertical Angle (35) (Through Max. Cd.)

PLF-100-50

ISOCANDELA CURVES

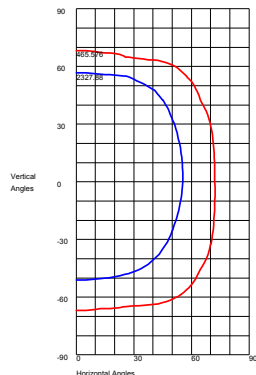

Maximum Candela = 4655.76 Located At Horizontal Angle = 5, Vertical Angle = 0
50% Maximum Candela = 2327.88
10% Maximum Candela = 465.576

ISOFOOTCANDLE LINES OF HORIZONTAL ILLUMINANCE

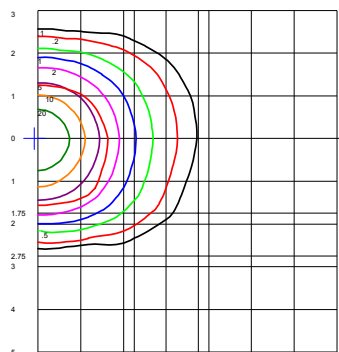

Distance In Units Of Mounting Height
Values Based On 10 Foot Mounting Height
1/2 Maximum Candela Trace Shown As Dashed Curve
(+) = Maximum Candela Point

AXIAL CANDELA DISPLAY

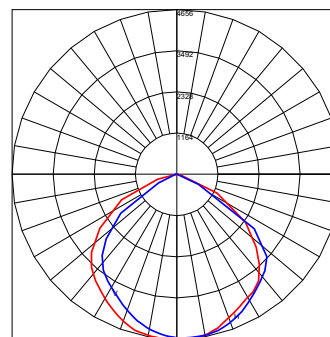

Maximum Candela = 4655.76 Located At Horizontal Angle = 5, Vertical Angle = 0
H - Horizontal Axial Candela
V - Vertical Axial Candela

POLAR GRAPH

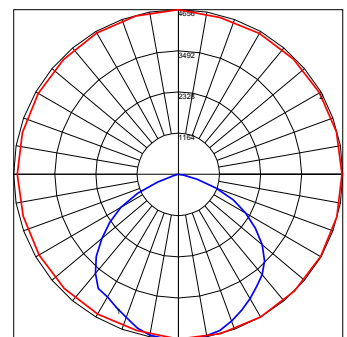

Maximum Candela = 4655.76 Located At Horizontal Angle = 270, Vertical Angle = 5
1 - Vertical Plane Through Horizontal Angles (270 - 90) (Through Max. Cd.)
2 - Horizontal Cone Through Vertical Angle (5) (Through Max. Cd.)

PLF-150-50

ISOCANDELA CURVES

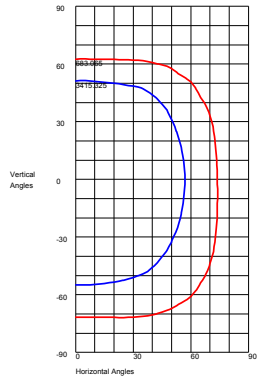

Maximum Candela = 6830.65 Located At Horizontal Angle = 5, Vertical Angle = 0
 50% Maximum Candela = 3415.325
 10% Maximum Candela = 683.065

ISOFOOTCANDLE LINES OF HORIZONTAL ILLUMINANCE

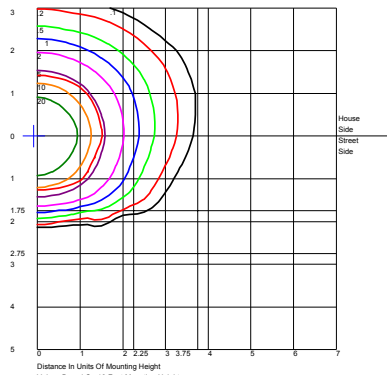

Distance In Units Of Mounting Height
 Values Based On 10 Foot Mounting Height
 1/2 Maximum Candela Trace Shown As Dashed Curve
 (+) = Maximum Candela Point

AXIAL CANDELA DISPLAY

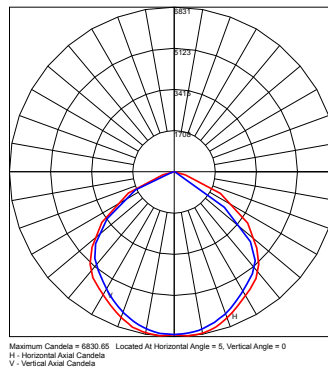

Maximum Candela = 6830.65 Located At Horizontal Angle = 5, Vertical Angle = 0
 #1 - Horizontal Axial Candela
 #2 - Vertical Axial Candela

POLAR GRAPH

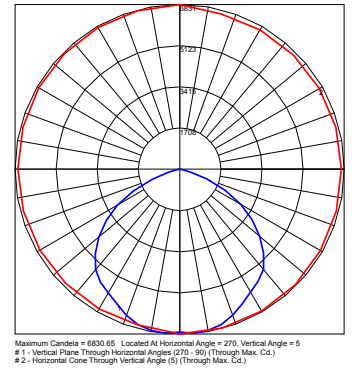

Maximum Candela = 6830.65 Located At Horizontal Angle = 270, Vertical Angle = 5
 #1 - Vertical Plane Through Horizontal Angles (270 - 90) (Through Max. Cd.)
 #2 - Horizontal Plane Through Vertical Angle (5) (Through Max. Cd.)

Electrical Accessories



Photocell



Motion Sensor



1-10V Dim

FSP-221B-D*
BiLevel Sensor
IP66 Rated
110-480V



Load Ratings	@120V 0-800W tungsten, ballast, LED driver; 1/6hp motor @230-240V 0-300W ballast, LED driver @277V 0-1200W ballast, LED driver; 1/6hp motor @347/480V 0-1200W ballast, LED driver
0-10V Sinking Current	50mA
High/Low Modes	high:0-10V, low: off, 0-9.8V
Time Delay	30 sec, 1-30 min
Cut Off Delay	none, 1-59 minutes, 1-5 hours
Sensitivity/Service mode	low, med, max: on-fix, off-fix
Setpoints	hold off setpoint: none, 1-250 fcs, auto photocell on/off setpoint: 1-250fcs
Ramp and Fade Times	1-60 sec
Op Temperature	-40°F to +167°F (-40°C to +75°C)

Dimensions

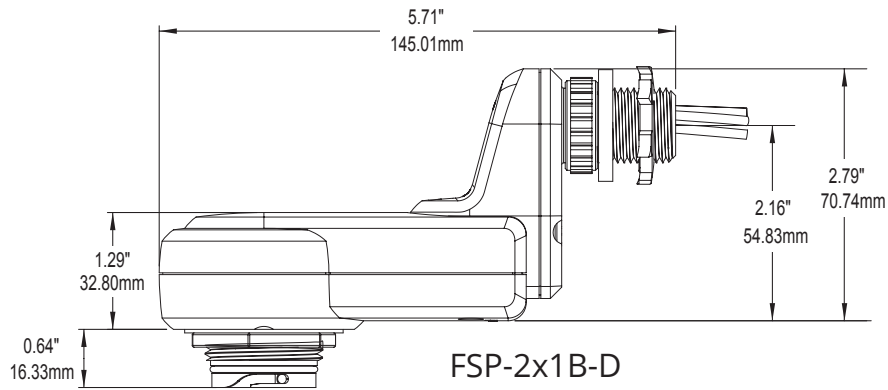

Wiring

Wiring with non-dimming load.

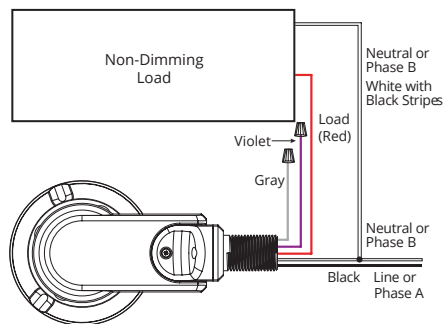

Wiring with dimming load.

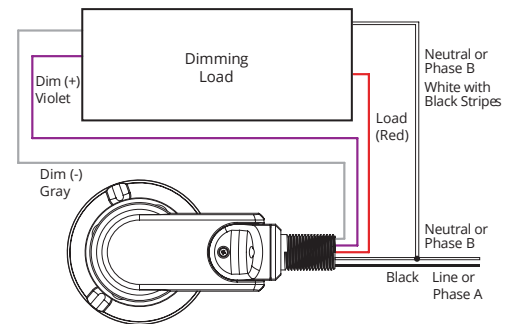

*See Sensor Specs sheet for more information

10 Year Warranty

ATG Electronics®
Industry Leading 10 Year Limited Warranty
For North American LED Lighting Fixtures

ATG Electronics warrants to the original purchaser of ATG Electronics Domestic LED products listed above that were manufactured for which the ATG Electronics Spec Sheet located on our website contains the words "10 year limited warranty" that, subject to the below terms and conditions of this warranty, when such LED products are properly installed they will comply with ATG Electronics published product specifications for such products and will be free from material defects in material and workmanship for a period of ten (10) years from the date of sale by ATG Electronics, or, if lesser, 50,000 hours of operation (at an average of 13.6 hours per day operation). The LED arrays in the Product(s) will be considered defective in material or workmanship only if a total of 15% or more of the individual light emitting diodes in the Product(s) fail to illuminate.

The above express limited warranty is extended by ATG Electronics® only to the original or first end-user purchaser and only for the original installed location. This warranty only applies to products purchased after June 1, 2017. This warranty is non-transferrable, whether by assignment or operation of law. The original purchaser must provide warranty claims to ATG Electronics within the warranty period promptly upon discovery and in accordance with ATG Electronics Return and Repair Procedures as outlined within this document.

Should any defects be found by ATG Electronics upon its inspection of the properly returned product, ATG Electronics sole responsibility and liability under this warranty will be, at its option, to either repair or replace the defective part or parts or else make available a new replacement unit that will provide equal or better performance. All decisions regarding the existence or non-existence of defects or otherwise affecting the warranty shall be made by ATG ELECTRONICS and shall be final and binding on all parties. Where a defective LED product is replaced under this warranty, the balance of the original warranty period shall remain effective.

Conditions and Exclusions

This warranty is conditioned upon proper installation, use and maintenance. This warranty will automatically become null and void and shall not be applicable to any LED fixture which (i) has not been timely paid for, (ii) is not installed and operated in accordance with the current edition of The National Electric Code (NEC), the Standards for Safety of Underwriters' Laboratory, Inc. (UL) or with ATG Electronics instructions and guidelines, (iii) has been moved from its original installation, (iv) has been installed within an area that has exposure to sulfur or any area with high acidic compounds in use, (v) has been operated in an ambient temperature or humidity that is higher than 35 degrees Celsius, (vi) has been subjected to a lightning strike, power surge or overvoltage condition, (vii) has its LED Board subjected to static electricity due to failure to discharge same prior to connecting or disconnecting the lead from the LED board, (viii) was not installed and/or operated in accordance with ATG Electronics instructions and guidelines, (ix) has been mishandled, misused, abused, tampered with, modified or altered by anyone other than ATG ELECTRONICS, (x) has been subjected to abnormal stresses and operating conditions, or (xi) has been operated without overvoltage and lightning protection devices in place.

Limitations

Disclaimers & Limitations of Liability

The foregoing warranty is exclusive of all other statutory, written or oral warranties and no other warranties of any kind, statutory, by operation of law or course of performance, or otherwise, are given, herein expressed or otherwise received. EXCEPT AS EXPRESSLY PROVIDED ABOVE, ATG ELECTRONICS DISCLAIMS ALL REPRESENTATIONS, WARRANTIES AND CONDITIONS OF ANY KIND, EXPRESS OR IMPLIED, REGARDING THE LED PRODUCTS AND ITS SERVICES, INCLUDING, WITHOUT LIMITATION, THE IMPLIED WARRANTIES OF MERCHANTABILITY AND FITNESS FOR A PARTICULAR USE OR PURPOSE.

LIMITATION OF LIABILITY. Other than the obligation to repair or replace as provided above, ATG Electronics shall have no liability for any losses, expenses or damages as a result of the installation, use, inability to use, removal or replacement of any LED product. ATG Electronics will not under any circumstances whether as a result of breach of contract, breach of warranty, tort, strict liability or otherwise be liable for consequential, incidental, special or exemplary damages including but not limited to, loss of profits or revenues, loss of any other goods or associated equipment or damage to any associated equipment, cost of capital, cost of substitute products, facilities or services, down time cost or claims of claimant's customers. ATG Electronics liability on any claim of any kind for any loss or damages arising out of, resulting from or concerning any LED product, any aspect of this warranty or for any products or services furnished hereunder shall not exceed the price of the fixture which gives rise to the claim.

Return and Repair Procedures

All warranty requests and or questions are to be directed to ATG Electronics Customer Service Department (CSD) at 888-618-7298. If deemed necessary, the CSD will issue a Returned Merchandise Authorization (RMA) number which must be included on both the packing slip of the component or fixture being returned and on the outside of the box. You must include your name and contact information, including your email address, on the packing slip so that we can contact you easily. Each component or fixture must be packaged very carefully and properly so as to prevent damages in shipment and must be shipped freight prepaid. Please obtain a proof of delivery to ensure that the material is received.

Once the component or fixture has been received and tested, an evaluation report will be provided to the end user via email. This report will clarify the following:

- A) The component / fixture is covered under the warranty policy and will either be repaired or replaced.
- B) The component / fixture is not covered under the warranty policy and the reason for this determination.

If ATG ELECTRONICS determines that the component or fixture is covered under the warranty, then the appropriate repairs will be started or a replacement fixture will be manufactured and shipped. Please note that in the event the returned component or fixture is found not to be covered under this warranty, you may be subject to a labor charge for the evaluation process and will be responsible for all return shipping charges and fees. For components and fixtures determined to be covered under this warranty prior to the first anniversary of the Sale Date, the repaired or replacement component or fixture will be returned to you at no charge. You will be responsible for all other shipping charges.

No Labor Reimbursement

All components and fixtures determined to be covered by this warranty as provided above, will be repaired or replaced at no charge to the customer, however, except as expressly provided above with respect to recessed and linear fixtures during the first year, the customer must hire and pay for an electrician to remove and reinstall such components and fixtures. No labor costs will be covered for the removal or reinstallation of any components or fixtures. The warranty does not cover modifications, repairs or replacements, or the related labor or materials costs, that may be necessary to facilities or third party products in connection with the removal, repair, or replacement of any LED product under this warranty.