

XLG-CLP-3040 is strongly built with precision die cast aluminum and with a chip/fade resistant powder coat finish. It is suitable for various outdoor environments. XLG-CLP-3040 is commonly ideal for: wall washing, parking areas, entrances, walkways, and underpasses. The XLG-CLP-3040 offers competitive pricing. 5 Year/50,000 hour limited warranty.

**FEACTURES**

- Energy Savings: Over 66% compared to HID light sources.
- Improved lumen maintenance.
- Operating temperatures: -30°C ~ 60°C.
- Driver: Constant current, 120-277v, 50/60Hz, 480v (Optional).
- IP66 Rated.
- Operating Life: >50,000 hours

**CONSTRUCTION**

- Housing Heavy-Duty Aluminum Housing.
- 3 Mill Powder Coat Finish, (Various colors available) (Custom).
- Silicone Gasket to prevent leakage and provide IP-66 Rated Product.
- Mounting: Swivel Bracket, Slip Fitter.



Example: XLG-CLP-3040-400LED-40K-SB-MV-BRZ

Cat #	Wattage	Color Temp.	Color	Voltage	Finish
<b>XLG-CLP-3040</b>	<b>400W (400LED)</b>	<b>4000K (40K)</b>	<b>Slip Fitter (Over 2" 3/8 O.D) (SF) Swivel Bracket (SB)</b>	<b>120-277V (mv)</b>	<b>Bronze (BRZ)</b>

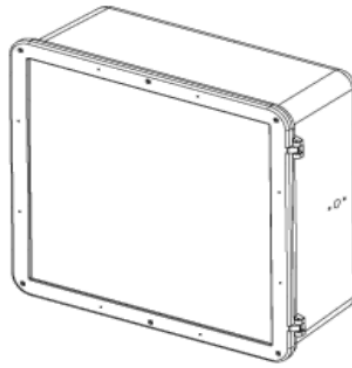

**Dimensions**

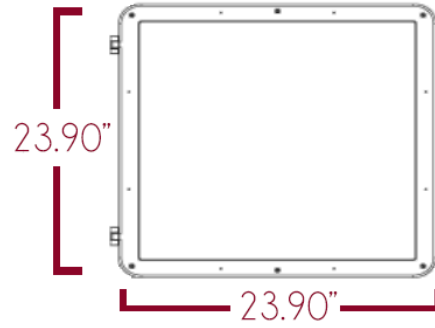
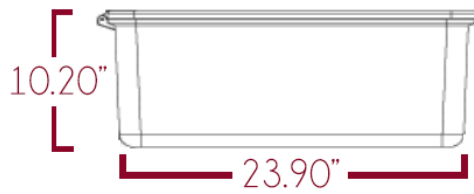

Cat #	Input Power	Lumen Output	LPW	Color Temp. (CCT)	CRI	Rated Life (L70)	Input Voltage	Input Voltage
XLG-CLP-3040-400LED	400W	44,723	116	4000K	80+	>50,000	120-277V	50/60HZ