

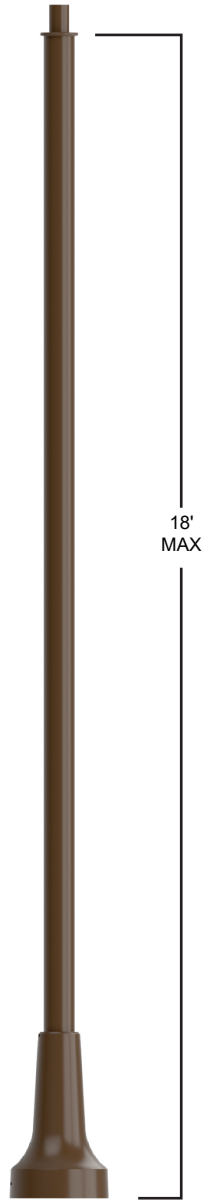

POLES & LIGHTING

AVPL LA - 11 SB - Los Angeles 11 Split Base (2 piece)



Description

The Los Angeles 11 Split Base is ideal for courtyards, pathways, municipal, and commercial decorative light pole applications.

Materials

Mounts to 4" and 5" smooth or fluted .250" aluminum shaft.

2 piece corrosion resistant cast aluminum construction with minimum wall thickness of .210"

Stainless steel hardware.

TGIC thermoset polyester powder coat finish is electrostatically applied at a 3.0 mil nominal thickness. A five stage metal pre-treatment process and sealer provide maximum corrosion resistance. The powder top coat is baked in excess of 400 degrees for supreme endurance.

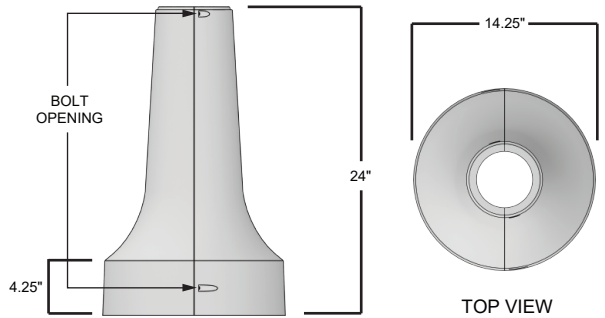

Ordering Information

Base	Shaft	Wall	Height	Finish
AVPL-LA-11 SB <input type="checkbox"/>	4S (smooth) <input type="checkbox"/>	<input type="checkbox"/> .250	<input type="checkbox"/> 10'	<input type="checkbox"/> Dark Bronze
	4F (fluted) <input type="checkbox"/>		<input type="checkbox"/> 12'	<input type="checkbox"/> Black
	5S (smooth) <input type="checkbox"/>		<input type="checkbox"/> 14'	<input type="checkbox"/> White
	5F (fluted) <input type="checkbox"/>		<input type="checkbox"/> 16'	<input type="checkbox"/> Grey
			<input type="checkbox"/> 18'	<input type="checkbox"/> Green