

LED Square Post Top Light



Description

The Square Post Top LED Lighting Series is a reliable, water resistant fixture that is best suited for outdoor applications. Whether you're looking to illuminate lawns, courtyards, or roadways, the LED Square Post Top will provide even and reliable illumination.



Applications

Parking Lots
Educational

Courtyards
Parks

Outdoor Retail
Roadways

Spec Summary

Efficacy 135 lm/W
Input Voltage 120 - 277V
Finish Dark Bronze

Details

IP Rating Wet Location / IP66
Material Aluminum
L70 Life + 75,000 Hours
Warranty 5 Year Warranty
CRI+ 70+
CCT 4000K/5000K
Qualification UL, DLC Premium, FCC, RoHS
Operating Temp -30°C - +45°C
Power Factor 0.90

LED Square Post Top

Product Information

ORDERING/DLC #:	Wattage	CCT	Lumens
U-SPT-60W-40	60W	4000K	8520 lm
U-SPT-60W-50	60W	5000K	8520 lm



LED Square Post Top Light

DIMENSIONS

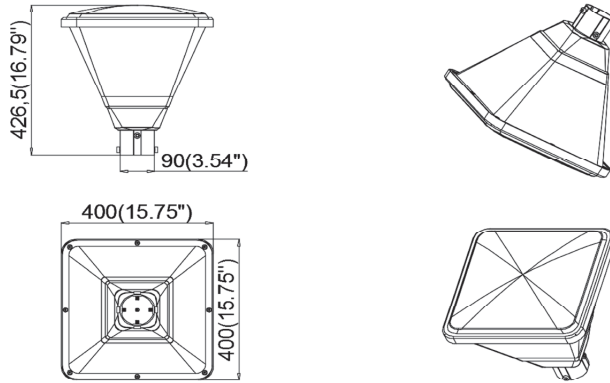

Structure Features:

- Shell Materials: Aluminum & PC
- Finish: Dark Bronze/White/black(Optional)
- Net Weight: 6.2KG (13.7LBS)
- Product Size: 400mm*400mm*426.5mm
- Carton Size: 450mm*450mm*480mm

PHOTOMETRY:

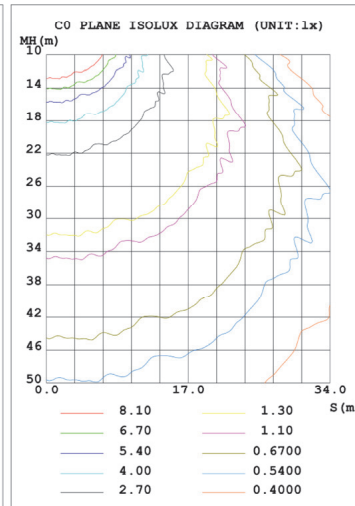
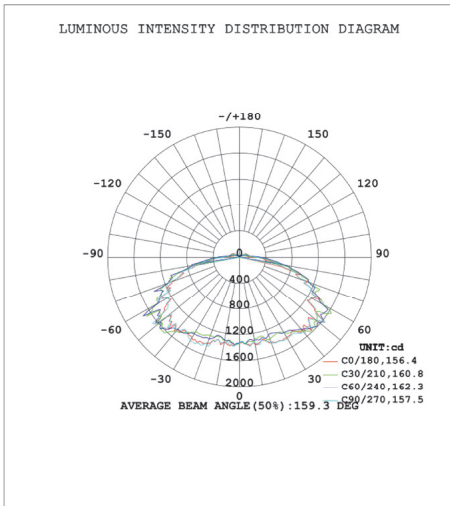

1.219m	54.57, 925.51lx	1168.71cm
2m	20.28, 343.91lx	1917.17cm
3m	9.012, 152.91lx	2875.76cm
4m	5.069, 85.981lx	3834.35cm
5m	3.244, 55.031lx	4792.93cm
6m	2.253, 38.211lx	5751.51cm
7m	1.655, 28.081lx	6710.10cm
8m	1.267, 21.501lx	7668.68cm
9m	1.001, 16.981lx	8627.27cm
10m	0.8111, 13.761lx	9585.85cm