



Illumination

- Adjustable long lasting, efficient ultra-bright white LED lamp heads which provides optimal center-to center spacing.
- 2 X 1.2W lamp head(12X0.1W white LEDs), 205 lumen output.

Electrical

- Dual 120/277VAC input.
- Charge rate/power"ON"LED indicator light and push-to-test switch for mandated code compliance testing.
- 3.6V 1000MAH long-life, maintenance-free, rechargeable Ni-Cad battery. 3.6V 2000MAH long-life, maintenance-free, rechargeable Ni-Cad battery for models with remote heads.
- Internal solid-state transfer switch automatically connects the internal battery to LED board for minimum 90-minute emergency illumination.
- Fully automatic solid-state, two rate charger initiates battery charging to recharge a discharged battery in 24 hours.

Mounting

- Universal J-box mounting pattern.
- Suitable for wall or ceiling mount.

Housing

- Injection-molded, engineering grade, 5VA flame retardant, high-impact resistant, thermoplastic in white or black finish.
- UL 94v-0 flame rating.

Options

- Remote lamps available.
- Remote load capability is up to 2W, compatible with two 1-lamp remote heads or one 2-lamp remote head (RH01 Series).

Warranty/Listing

- Five years warranty on all electronics and housing. Batteries 3 years.
- Meets UL924.
- UL listed for damp locations (0° -40°).

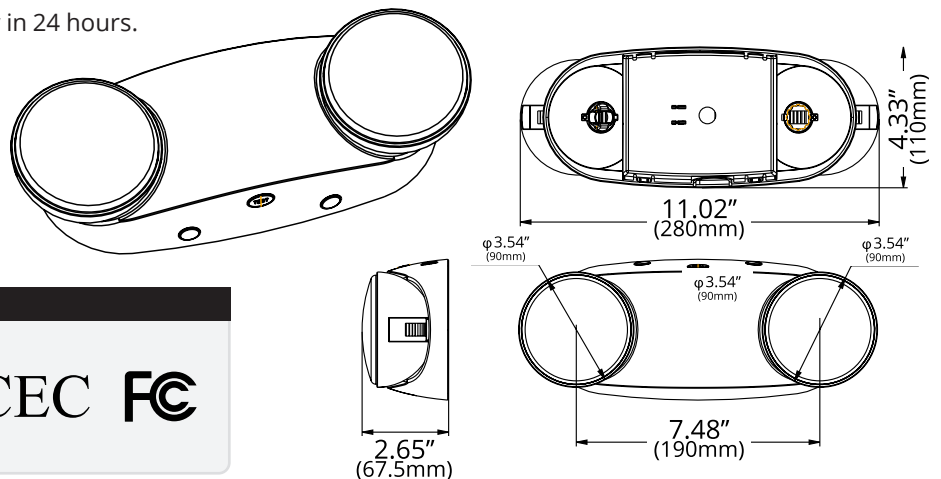

Certifications and Compatibilities



Order Format

Example: EML01-WH

Series	Voltage	Finish Color	Other Options
EML01	Blank=120-277V	WH=White	Blank RC=with Remote Load*

* Remote load comes as default (RH01 Series)