

L-856 CM Series White LED High Intensity Obstruction Light

Compliance&Approval:

- ICAO Annex 14, Volume I, 6th Edition, July, 2013
- ICAO Aerodromes Design Manual, Chapter 18
- FAA AC150/5345-43G
- FAA Engineering Brief 67 Specifications
- Certified to ICAO compliant by Intertek

Applications:

- ICAO high intensity Type A
- ICAO high intensity Type B
- FAA L-856 type
- FAA L-857 type

Advantages:

- ICAO Approval.
- LED low power consumption less than 100 Watts average.
- Fixture can be used with 100V~250V AC, 50Hz or 60Hz.
- Special optical reflector design, further visual distance and no light pollution.
- Internal single chip computer control smart and reliable.
- Surge protection device integrated in the light.

Technical Features:

- Operation voltage:100V~250V AC,50HZ/60HZ.
- Lamp:100,000 hours high quality LED.
- FPM:40~60 flashes/per minute pre-set in factory.
- Color:White.
- Output:90° horizontal; 3° vertical.
- Photo sensor:50~500Lux
- Lighting protection level:10KA
- Housing: casting aluminum&tempered glass window.
- Finish: UV stablized spraying plastic.
- Overall size: 47cm×20.4cm×13.4cm.(18.5''×8''×5.2'')
- Mounting size: 44.5cm×7cm-4×M10.
- IP rating: IP65.
- Weight: 8KG.
- Operating: -40°C to 60 °C.
- Wind speed: 80m/s.

Optical:

- Daytime: Light intensity at elevation angle 0°, -1° and beam spread degree compliant to ICAO.
- Twilight: Light intensity at elevation angle 0°, -1° and beam spread degree compliant to ICAO.
- Night: Light intensity at elevation angle 0°, -1° and beam spread degree compliant to ICAO.
- Chromaticity compliant.

Details of photometric data please contact us.



The CM series obstruction beacon utilizes state-of-the-art optical design to achieve smaller, efficient and lower consumption. Its robust will provide years of maintenance free service. It will be the user's best choice to protect their benefits.

It is used increase conspicuity of structures or obstructions during all day/24Hours.

Widely used in any obstruction like TV towers, high-rise buildings, chimney, telecom towers, transimission power towers, airports,wind turbines and crane machines.

General Dimensions

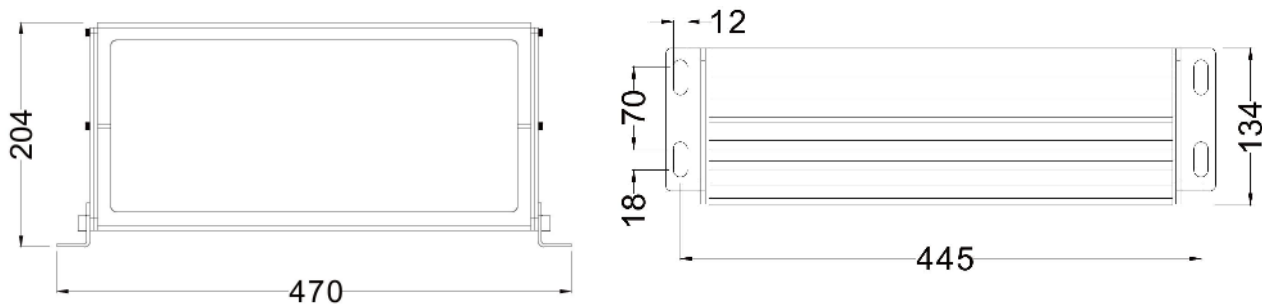

Ordering Code:

Type	Flash	FPM ¹	Lamp	Synchronized Method	Housing Finish Color	Sensor Control	Monitor
18/Type A	F: Flashing	40	AC: 100/250V	00 ²	Y: Yellow	I: Integrated ⁴	CP ⁶
17/Type B		60	DC: 10/24V	SC ³ GPS	S: Silver	E: External ⁵	

¹ FPM:Flashes per minute

² 00: Standard single light, 3 core cables pre-wired, independently flash, can not synchronized flash with other lights.

³ SC: Signal cable controlled, 4 core cables pre-wired, multiple lights synchronized flashing without control panel.

⁴ I: Integrated photo sensor built in light, no need additional photo sensor.

⁵ E: External photo sensor, work with the control panel box together.

⁶ CP: Separate order the CP "control panel", for a purpose of light failure monitor and control function.