

# APOLLO™

## Solar Flag Pole Light

Our Apollo 1890 lumen solar flag pole light is a set of three light heads, each containing 6 bright LEDs covers 360 degree angle. Each head can be individually adjusted to beam at different directions using 180 degree knob adjustment. Apollo Solar panel is glass protected and the light heads are made from die cast aluminum. The light is designed to come on/off automatically from dusk to dawn.

- Compact and easy to install at the middle of pole, does not require you to reach top of the pole.
- Unique curved appearance and completely solar powered
- Adjusting the solar panel angle maximizes solar collection and allows snow to slide off
- Our flagpole light is safe outdoors and operates with the included self-charging batteries
- 1890 Lumen, IP65 Rated
- 1 Year limited warranty



# APOLLO™

## Solar Flag Pole Light

### Specifications

Model #	SKU #	Power	PV Type	Solar Panel	Lithium Battery	Lumens	CCT	IP Rating
AVS-JY8-829	990203	18W	MONO	16W	15000 mAh	1890LM	6000K	IP65



### Features

- IP65 Rated
- Compact System
- Unique curved appearance
- 100% Less Power Consumption
- Automatic Day & Night Detection
- Pury LED 1W LED Chips
- Completely Solar Powered
- Lithium-ion battery
- 1890Lm & 6000K
- Emitting Color: White

### Applications

- Flagpoles
- Government Buildings
- Memorials
- Historic Sites
- School Playgrounds & Gardens
- Campuses, Parks, & Yards
- Boat & Loading Docks
- Farms & Ranches
- Remote & Wildlife Areas
- Parking Lots & Military Bases

### Correlated Color Temperature

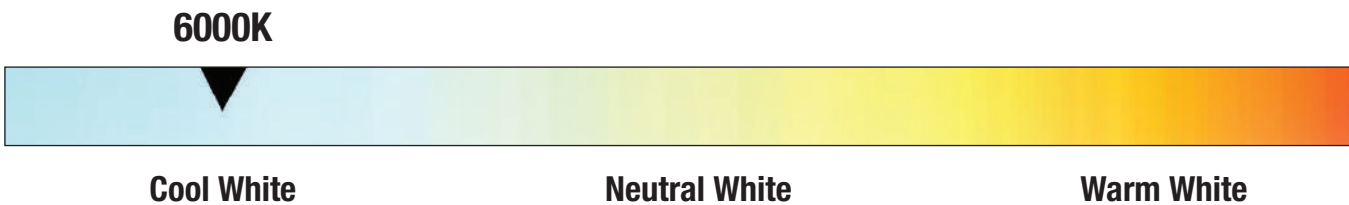

# APOLLO™

## Solar Flag Pole Light

### Product Design and Benefits

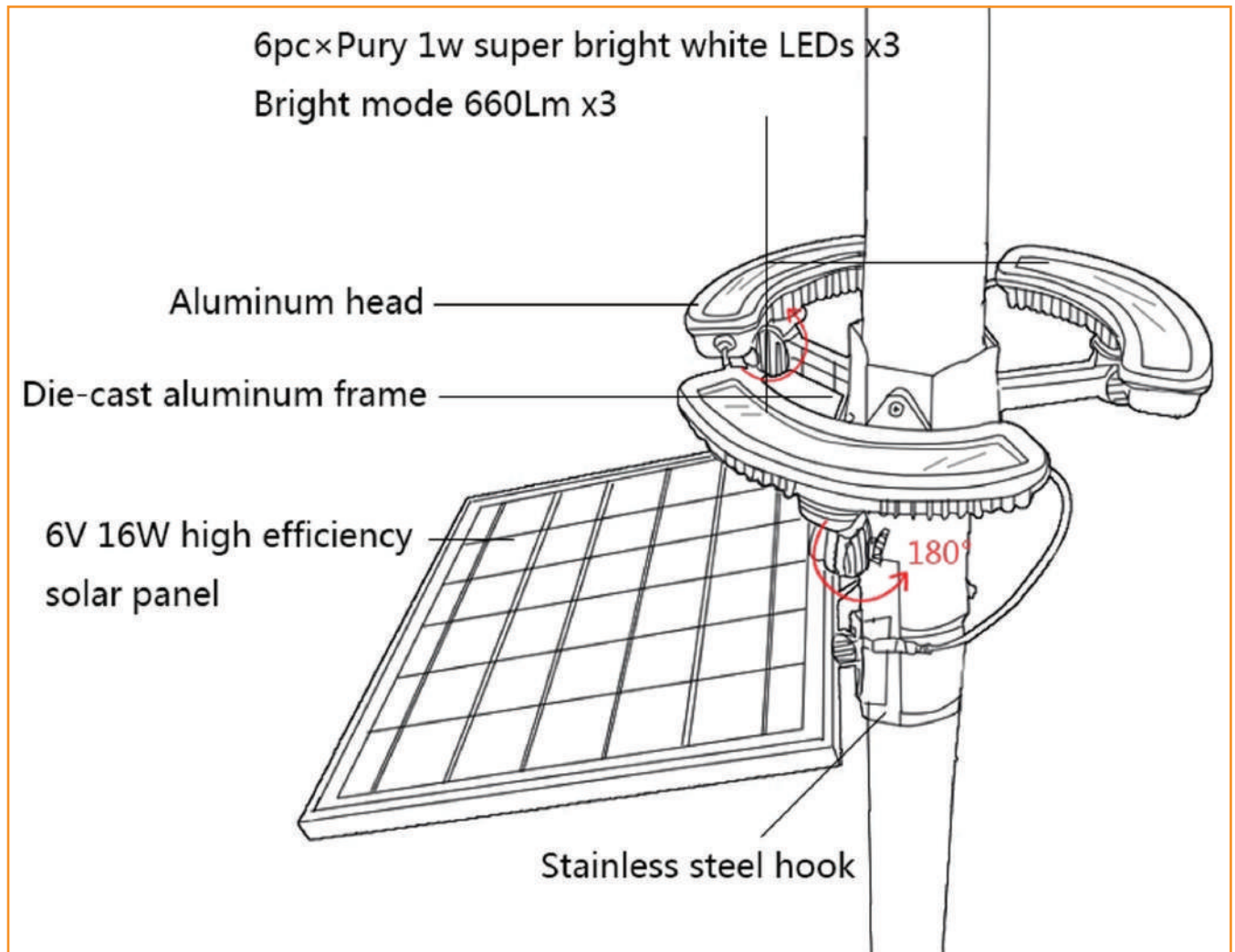

### Dimensions

16.33858x15.55118x5.51181”

Can be aimed Up or Down at Monuments





# APOLLO™

## Solar Flag Pole Light

### Product Design and Benefits

- Brightness: 660Lm x 3 = 1890 Lm
- Materials: Aluminum head, Die-casting aluminum frame, Stainless steel hook, & Glass panel
- Battery: 3.7 V 15000mA Lithium rechargeable battery
- Solar panel: 6V 16W
- LED Qty: 18 pieces ( 6 Pcs x Pury super bright white LED 1W) x3
- Waterproof: IP65 Rated
- Lasting time: up to 12 hours when fully charged
- Switch: Auto switch on/off from dusk/dawn (with button switch)
- Application: flag light/garage/backyard/walkway/porch



18 LED SOLAR FLAGPOLE LIGHT	
Model No.	AVS-JY8-829
Solar Panel	6V / 16Wp
IP Rating	IP65
Material	Aluminum, Stainless steel, Glass Body
Product Color	Black
Battery Type	Lithium-ion battery pack
Battery Capacity	3.7 V 15000mA
Working Time	≥12 Hours
LED Type	18 pieces of 1W Pury
Luminous flux	660Lm x 3 = 1890 Lm
Emitting Color	White

### Installation

Please place your light in the direct sun for 12 hours prior to first use.

- You can cover the panel in the daytime to make the light “think” that it’s night, and the light will turn ON then.



### Advantages

- Energy saving, long lifespan
- Light is soft and uniform, safe to eyes
- Instant start with no flickering or humming
- Green and eco-friendly without mercury
- Durable construction for long time use
- Aluminum, Stainless steel, Glass Body
- No monthly electric bills
- Battery backup for cloudy days
- No power outages
- No line voltage, trenching/metering
- Easy to install & operate - <1 hour
- High performance lithium battery



# APOLLO™

## Solar Flag Pole Light

### Super Bright Pury LEDs

Project to a wider coverage area than other LED beads.

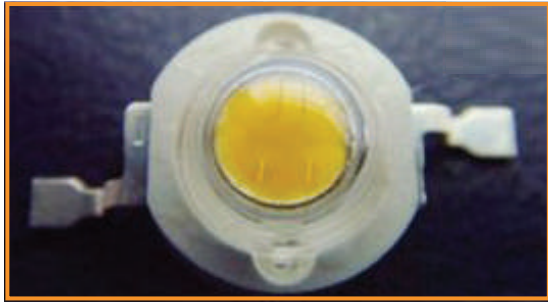

Beyond Solar's 18 LED Solar Flagpole Light is a set of three light heads; each containing 6 ultra-bright Pury LEDs which can all at once efficiently cover a 360° angle or be individually adjusted to beam at different directions using a 180° knob adjustment. Pury LEDs are super bright, but they are at the brightest when in communion with each other. The triune can be used to light up a flag or to cast light down on your garden, garage, wall or surrounding areas. The light heads are made from aluminum, and the frames from die-cast aluminum. The solar panel is glass protected ensuring that its component parts are durably sustained. The 18 LED Solar Flagpole Light's brightness is a composite of 18 pieces of Pury 1W ultra bright LEDs that come together to give off a bright mode of 1,980 Lumens; steadily powered by a 3.7V-15000mA lithium rechargeable battery. Its battery power lasts up to 12 hours when fully charged by the 6V-16W solar panel. The light is designed to automatically come ON at dusk and go OFF at dawn. It is also accompanied by a button switch for manual operations. With the aid of stainless steel hooks, the setup can easily be attached to broader poles. Beyond Solar's 18 LED Solar Flagpole Light is of high standard value, with an IP rating of IP65, it assures you of a long lasting product that can withstand any weather conditions.





# APOLLO™

## Solar Flag Pole Light

### Application



SOLAR FLAG POLE LIGHTS



# APOLLO™

## Solar Flag Pole Light

### Instructions

#### User guide

Thank you for choosing The Solar Flagpole Light. This light is designed to mount on most commercial and residential flag poles. Using the light give allows you to properly display your flag at night. Please read these instructions carefully before using your light.

#### Product parts list

- A: 3 x Lighthead
- B: Mount
- C: Die-cast aluminum frame
- D: Stainless Round Hoop
- E: Solar panel

**PLEASE CHARGE YOUR LIGHT FOR 3 DAYS BEFORE FIRST USE**

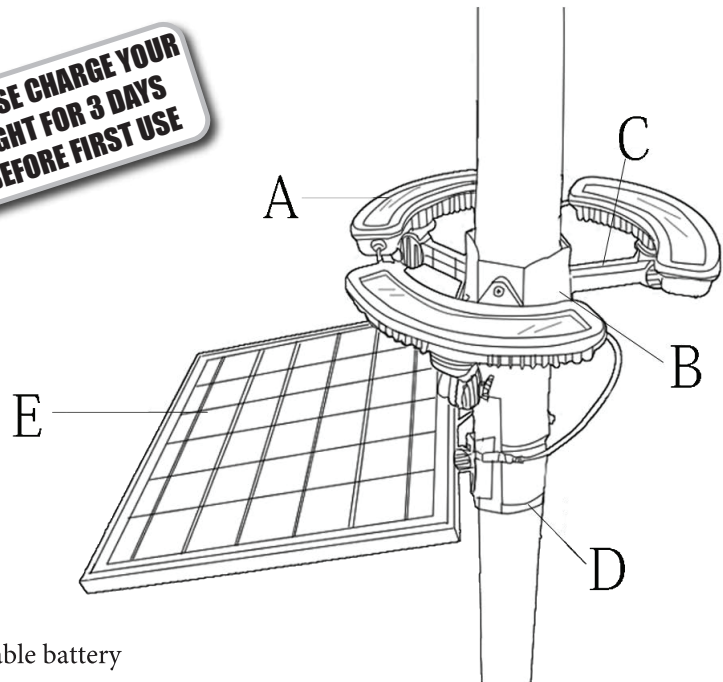

#### Specification

- 6V 16W solar panel
- 6 x 1W super bright white LED x 3
- 3.7V 15000mAh lithium rechargeable battery

#### Installation direction

1. Check to make sure the light is working properly. Turn the power switch to the On position and cover the solar panel, the light should turn on. If the light does not come on, push the On/Off switch again and cover the solar panel. Before mounting the light on any pole, make sure the light is turned on. Please note that the switch is set to the Off position during production.

2. Attach the solar panel and the light head to the die-cast aluminum frame frame using the provided nuts and bolts. Install the hoop with mount on your flag pole.

3. Move light to the desired mounting height (this depends upon the size of your flag). Once you have moved the light to the desired height, fully tighten the hoop to secure the light to the pole.

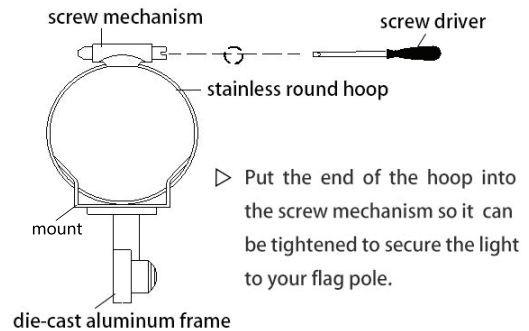

# APOLLO™

## Solar Flag Pole Light

### Instructions

4. Position the solar panel so it is facing the sun , the more direct sunlight the panel receives the better your light will function. The sun's position moves throughout the year, configure the solar panel so that it is aimed directly at the sun during midday, this will help you achieve the best charging opportunity for you batteries and ultimately the best performance of the light. For maximum performance the solar panel will have to be adjusted in the spring and fall.

**Please note a poorly positioned panel will stop the light illuminating for long after dark.**

#### Changing the batteries:

1. Remove the screws from the underside of the solar panel.
2. Lift the panel carefully ensuring the wires inside aren't strained.
3. Remove the batteries.
4. Replace with the same rechargeable battery as the original model.
5. Please recycle the old batteries.

**NOTE: Do not use the other battery to replace, this may cause damage.**

#### Frequently asked questions

##### 1. The light is dim or flashes

Batteries are not fully charged or may need replacing

The solar panel needs bright light to recharge the batteries. Consecutive days of overcast weather may cause the batteries to lose power. If this happens the solar panel will recharge the batteries on the next bright day.

Check for things obstructing light reaching the solar panel like over hanging branches, fences or buildings. If there are obstructions move the unit to a location receiving better light throughout the day.

Check the solar panel is clean. A dirty solar panel will not let the batteries charge fully. This will shorten the life of the batteries and stop the light operating. Clean the solar panel regularly with damp cloth.

##### 2. How long will the light illuminate my flag?

The length of time the light is illuminated is dependent upon several factors. The season, weather conditions and the location where you live (geographically) all affect the ability of the solar panel to charge the batteries, which will directly effect the duration of illumination. During most months, there is enough sunlight to recharge the batteries on a daily basis. The brighter and sunnier the day the better your batteries will charge and ultimately the longer it will illuminate the flag. When fully charged, the light should illuminate for close to 12 hours.



World Wide Panel Aiming





# APOLLO™

## Solar Flag Pole Light

### Optimum Panel Orientation

The Solar charge in a battery pack won't last forever. The off-grid system relies on stored solar energy for autonomy. Angling your solar panels properly can boost the power intake of your solar lighting system. You want to angle your solar panels at a tilt based on the area's latitude.

#### Tip for Maximum Power

You can increase the tilt 15° in the winter or decrease 15° in the summer. In this way you can get the maximum sunlight to recharge the battery.

### Best Facing Direction of Solar Panel

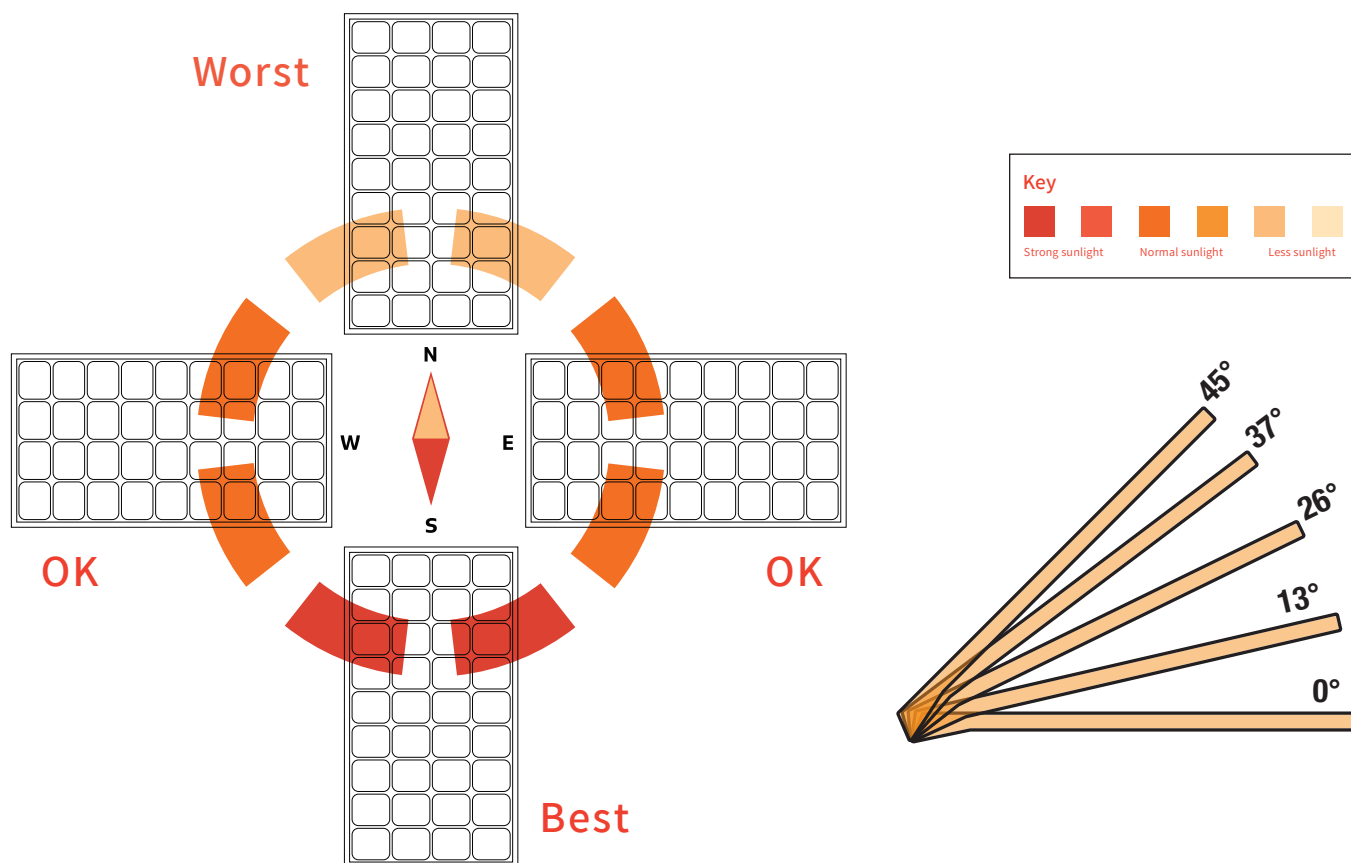

The area will dictate the installation of the fixtures and will sometimes prevent the lights from facing south. Panels facing West & East won't get as much light as Southern facing panels, but will still collect a good amount of sunlight. A North facing panel also works, but it will take longer to charge than any other direction. This would mean that the solar charge will be less optimal if installations are facing North.



# APOLLO™

## Solar Flag Pole Light

### Optimum Panel Orientation

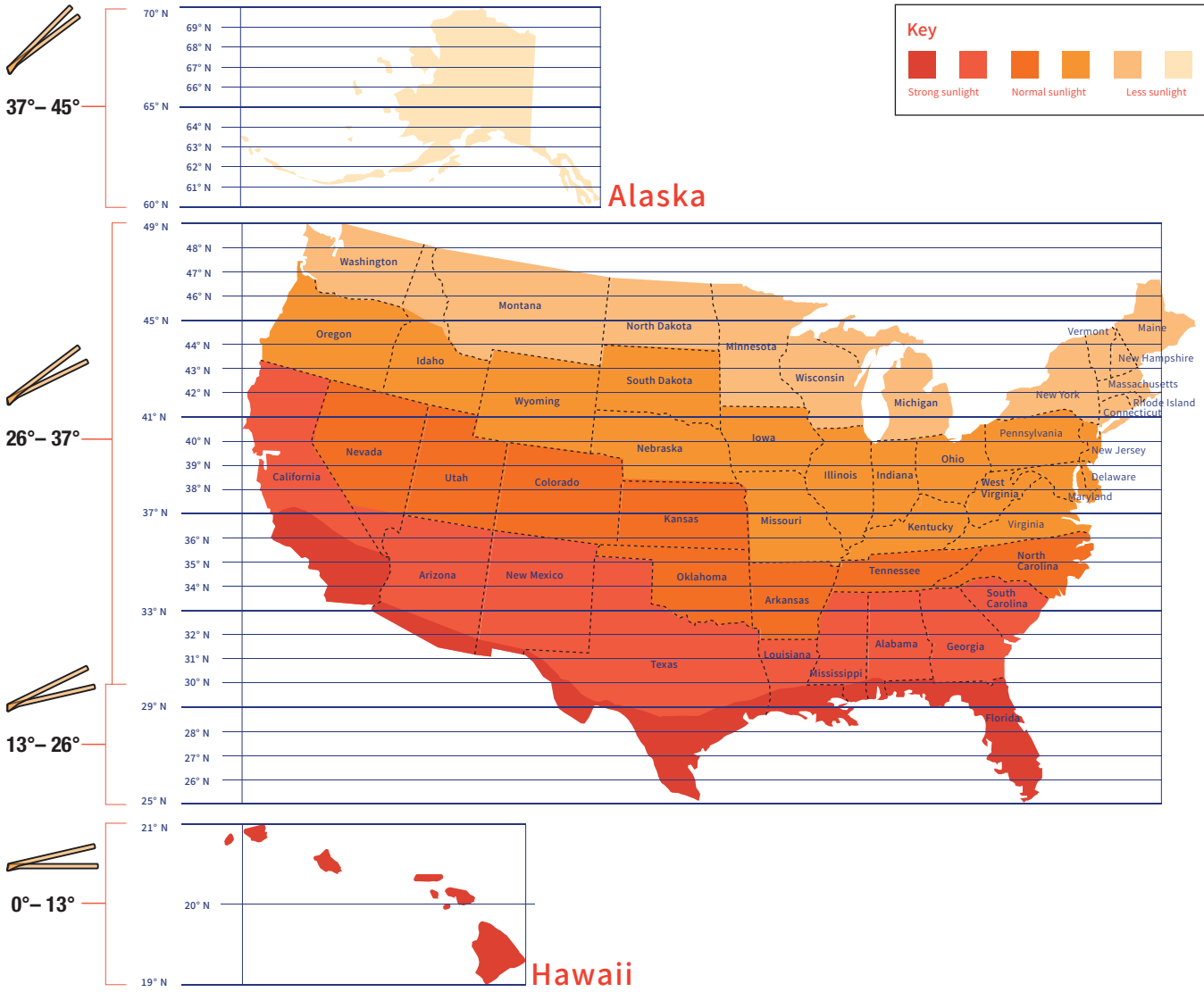

SOLAR FLAG POLE LIGHTS

