

## HL-50 LED 8" Flush Heliport Perimeter Inset Light

HL-50 flush heliport light proved to be reliable quality and installed at all kinds of helipads worldwide.

Heliport Perimeter Light is used for night operation, to use omnidirectional green perimeter light lit up the heliport TLOF/FATO edge area.

### Applications:

- Helipads at rooftop, surface ground, ships, helidecks, etc.
- Flush mounted marking edge of FATO area or TLOF area
- Flight path alignment lights
- Landing direction lights
- Taxiway edge lights-blue

### Compliant:

- ICAO Annex 14, Volume II, 4th Edition, July, 2013
- FAA AC150/5390-2C
- Exceeds FAA Engineering Brief 87 Specifications

### Why HL-50:

- Flush type, lens above the grade only 15mm after installations.
- Fixture can be used with 90V~265V AC, 50Hz or 60Hz.
- Heat&corrosion resistant lens ensure outdoor operation performance.
- Unique optical lens design exceed ICAO required optical performance.
- Consist of internal cap and external 8" base(base can).
- Reserved glands/cables at bottom base 1 in-1 out, easy installations.

### Optical Characteristics:

Elevation angle	Azimuth	Light Intensity
20° to 90°	-180° to 180°	>3cd
13° to 20°	-180° to 180°	>8cd
10° to 13°	-180° to 180°	>15cd
5° to 10°	-180° to 180°	>30cd
2° to 5°	-180° to 180°	>15cd

### Electrical Characteristics:

- Power by 90V to 265V AC, or 10V to 30V DC.
- <20W power consumption.
- Green color LED light source 100,000 hours lifetime.
- Dimming of brightness function available with customized controller.
- Switchable dual colors is available with customized controller.
- VHF control with customized controller.

### Drawings:

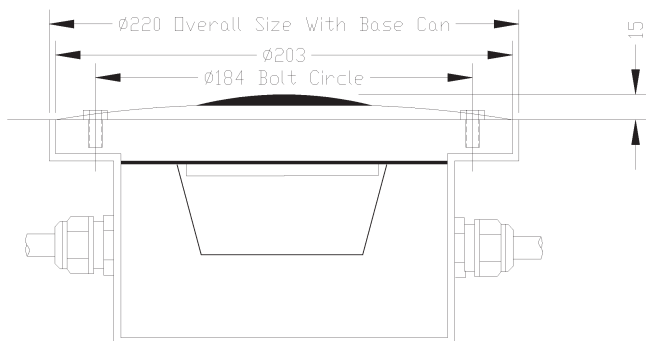

### Physical Characteristics:

- Die-casting aluminum bodys.
- All hardwares shall be stainless steel.
- Powder coating finish for the light.
- Heat&Corrosion resistant high borosilicate glass lens.
- Sealed&protected, ingress grade rating IP68.
- Diameter standard 8"/20.32cm, bolt circle 7.25inch/18.42cm.
- ø22cm external size with base can, 13cm in height.
- 5.5KG net weight.

### Environmental:

- Operating at -30°C to 70 °C.
- Wind speed: 80m/s.

### Ordering codes:

Type	Output	Lamp	Treatment
HL-50	G: Green B: Blue R: Red W: White Y: Yellow	AC: 100/250V DC: 10/30V VB: Variable brightness <sup>1</sup> SC: Switchable dual color <sup>2</sup>	MT <sup>3</sup>

<sup>1</sup> Variable brightness, 3 level brightness controlled.

<sup>2</sup> Switchable dual colors, omnidirectional, manual switch to Red/OFF/Green to realize a signal for pilots "Red" close to landing and "Green" available to land.

<sup>3</sup> MT type all hardwares on light shall be A4/316, sealing components like corrosion resistant O-rings, and sealants shall be marine type.

